

Colamark

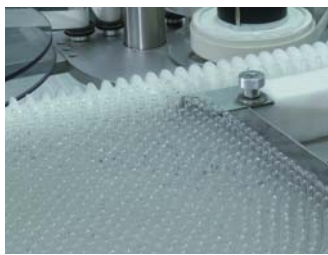

Colamark A105 Rotary Vertical Wrap-around Labeling System for Vials

A105 is specially designed for high speed and precision labeling on ampoules, vials, and other thin pharmaceutical bottles that cannot stand stably for transport. Tray-to-tray operation and spacing worm for convenient standalone operation. Rotary indexing table aligns bottles at three points enabling extra stability and high precision labeling at all speeds. Unique mechanism effectively avoids bottle breakage thus allows smooth operation at very high speed. Optional label and code inspection. Patented positive drive rejection wheel mechanism ensures accurate rejection of defective products orderly during high speed operation.



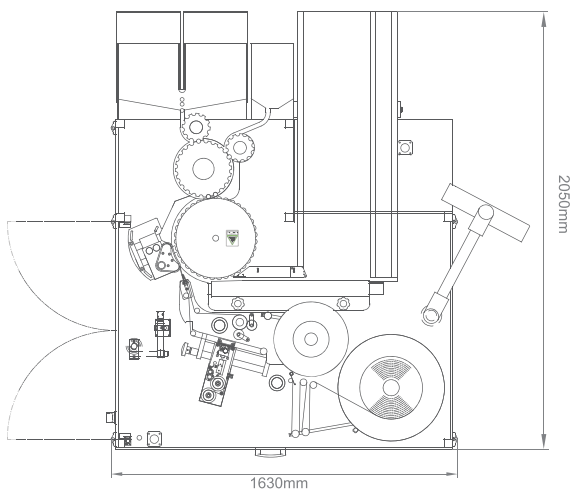
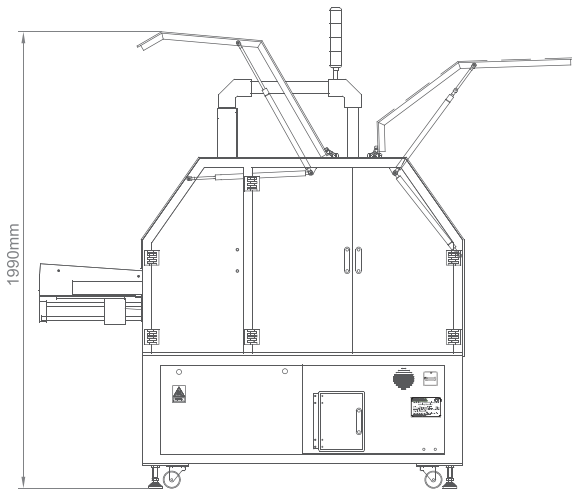

Features

- Vertical transportation of bottles in the full cycle. Good also for thin bottles that cannot stand stably by itself for transportation.
- Use of rotary turntable and feeding worms throughout the path for bottle movement and indexing to ensure bottle movement stability.
- Properly indexed bottle position to ensure inspection and rejection consistence.
- Various optional inspection devices including missing code detection, missing label detection, visual system inspection for label content and placement accuracy etc.
- Rejection device at fully indexed pace to ensure accurate rejection at high operation speed.
- Bottle is gripped at 3 points at labeling to ensure proper alignment between bottle and label.
- Tray-to-tray operation mode - Loading bay and discharge bays located in the same side for easy operator handling.
- Optional in-line operation mode. The large bottle buffer at the loading bay allows smooth connection with upstream equipment.
- Connects seamlessly to the Colamark tray insertion machines for tray insertion of the labeled bottles - another step of integrated automation at your packaging line.
- High speed operation at up to 600 bpm.
- Optional high speed hot stamping coder or thermal transfer overprinter at matching speed.
- Safety enclosure and safety door switches
- PLC controlled operation
- User friendly HMI with program memory.

Model

A105

Bottle diameter	10-30 mm (change parts needed)
Capacity	Up to 600 bpm (depending on material dimensions)
Alignment precision	± 0.5mm excl. errors from materials)
Options	No-label detection, no-code detection, barcode reading, Visual system for content inspection
Tray-insertion	In-line connection bridging device, Thermal transfer overprinter, High speed hotstamping coder, High resolution inkjet printer and curing heater
Power consumption	220VAC ± 5% 50Hz 4.1kW
Machine Dimensions	(L)2,050mm x (W)1,630mm x (H)2,100mm

(Custom engineered solutions are available to cater for customer's special needs.)

For continuous improvement on design and product innovations, all specification data are subject to change without prior notice

Colamark (Guangzhou) Labeling Equipment Limited

19 Jin Xiu Road, GETDD, Guangzhou, China

Tel: +86 20 8221 6718 Fax: +86 20 8221 5799 PC:510730

Colamark Technologies Limited

820 Topsail Plaza,11 On Sum Street,Shatin, Hong Kong
Tel: +852 2634 8011 Fax: +852 8161 3311 Email: info@colamark.com Web: www.colamark.com

|HongKong | Guangzhou | Kunming Chengdu | Wuhan | Chongqing | Xian | Shanghai | Qingdao | Beijing | Shenyang | Harbin|